

Installation instructions for Silvadec® reversible aluminium joists

Thank you for choosing a Silvadec® decking accessory! We hope you will be completely satisfied with your purchase, and will enjoy it for many years to come!

The recommendations for use below are additional to and in no way replace the instructions (PU7) for installing Silvadec® deck boards.

REVERSIBLE ALUMINIUM JOISTS



CONTENTS

SAFETY	2	INSTALLING BOARDS.....	12
OVERVIEW OF THE SYSTEM	2	Installation with single fastening clip	12
PRODUCT DATA	3	Butting boards	12
PLANNING / LAYOUT	4	Installing boards or finishing boards at the edge of the decking	13
General points.....	4	Removable clips.....	14
Layout	4	INSTALLING FASCIA BOARDS AND FINISHING BOARDS ON RISERS	14
Tools to have on hand	4	Option 1: exterior frame with full joists.....	14
PREPARING THE GROUND	4	Option 2: exterior frame with dividers.....	15
INSTALLING THE SUB-STRUCTURE.....	5	Option 3: no exterior frame	15
Pedestal-mounted	5	FINALISING THE INSTALLATION	16
Installing on spacers.....	5	ADVICE ON USAGE	16
INSTALLING THE STRUCTURE	6	MAINTENANCE ADVICE	16
Butting joists	6	END OF LIFE.....	16
Vertical connection as a finish.....	7	Disassembly.....	16
Reversible system for butting boards.....	8	Recycling potential, and disposal.....	16
Affixing dividers	8		
Decking surround	10		

SAFETY

To ensure that Reversil Aluminium joists are installed safely, suitable personal protective equipment must be worn during the work.

OVERVIEW OF THE SYSTEM

The Silvadec® aluminium joist is an alternative to joists made of wood or wood composite, for mounting on pedestals or on rubber/plastic expansion spacers. It offers a structural solution, especially for items installed on weather proofing (wet environment).

The reversible aluminium joist combines multiple functions that are very useful for the installer:

1. The joist's matt black colour does not shine, and renders the joist invisible under decking. This delivers an even finish.
2. The clip screws are held in place by several threads, thanks to internal guiding. This offers much greater pull-out resistance than when a screw only grips the thickness of the joist wall.
3. The Silvadec clips are always guided by a rail, and the special aluminium clip screws are guided using a screw centring line. This means that they are easier and faster to fit.
4. This clip rail is slightly deeper than the clip itself, so the deck board rests on the joist, rather than on the clip. As such, footsteps make very little noise and there is no sound from the aluminium joist.
5. Unlike for exotic wood which requires torque, drilling into aluminium calls for accurate guidance. Consequently, the clip screw heads have POZIDRIV engraving, suited to the guidance requirement in the first phase of drilling into the aluminium joist.
6. The joist has been devised as an entirely separate system. It is therefore supplied with installation accessories that suit its profile perfectly: connectors to lengthen it, horizontal and vertical brackets, matching screws with hexagonal heads. These accessories are guided along the side walls by alignment ribs, ensuring that the ensemble remains flat and rigid.
7. As for the clip screws, the side screws for affixing the connectors use a centring line to guide them. This means that they are easier and faster to fit.
8. A set of adjusting spacers (flat or notched) and rubber pads is available, serving to keep the joist off the ground and allow water run-off to escape.
9. When using Silvadec® reversible aluminium joists, boards can be butted onto a single joist. To enable this, the joists have two rails on their underside. They therefore need to be turned over, so that a single fastening clip can be fitted to each rail for butting the boards.

To make installation easier and give the structure more rigidity, it is advisable to make an exterior frame and install dividers between adjacent joist lengths.

PRODUCT DATA

Diagram	Reference	Name	Dimensions (in mm)	Principal material	Colour	Finish	Unit weight (kg)	Bulk packaging
	SILAMB2102	Silvadec REVERSIL Aluminium Joist, 3600 mm	63 x 40 x 3600 mm	Aluminium	Matt black	Powder coating	3.23 kg	120 items per palette
	SILAMBENT2101	337 mm alu divider for REVERSIL joist	63 x 40 x 337 mm	Aluminium	Matt black	Powder coating	0.3kg	25 items
	SILAMBCO2121	Foldable REVERSIL connectors + H8 screws, box of 25 items	Connector: 4 x 120 x 1.5 mm Screws: H8 4.8x25 mm	Stainless steel	Natural	-	1.1 kg	10 boxes
	SIEQH2121	Horizontal REVERSIL brackets + H8 screws Box of 50 items	Bracket: 34 x 60 x 60 mm Screws: H8 4.8x25 mm	Stainless steel	Natural	-	2.2 kg	10 boxes
	SIEQV2121	Vertical REVERSIL brackets + H8 screws Box of 25 items	Bracket: 60 x 60 x 1.5 mm Screws: H8 4.8x25 mm	Stainless steel	Natural	-	1.33 kg	10 boxes
	SICLIP2102	Single fastening clips + stainless steel screws for alu joists Bag of 36 items	Clip: 37.6 x 20 x 30.8 mm Screws: PZ2 3.9x25 mm	Stainless steel	Natural	-	0.54 kg	30 packets
	SICLIP2111	Start and end clip, compatible with REVERSIL Bag of 10 items	Clip: 37.6 x 20 x 30.8 mm Screws: PZ2 3.9x25 mm	Stainless steel	Natural	-	0.13 kg	100 bags
	SICALE2103	Rubber pads 78x78x8 mm in 24-item pack	78 x 78 x 8 mm	Rubber	Black	-	1.05 kg	50 packets
	SICALE2101	Flat spacers from 1 to 5 mm Box of 400 items	Thickness = 1, 2, 3, 4 or 5 mm 100x24 mm	Polyethylene	Blue, Black, Red, White, Yellow	-	2.27 kg	10 boxes
	SICALE2102	Notched spacers from 8 to 25 mm Box of 245 items	60 x Orange: 80 x 40 x 8 mm 70 x Green: 80 x 30 x 10 mm 75 x Brown: 90 x 45 x 15 mm 40 x Yellow: 150 x 45 x 25 mm	Polyethylene	Orange, Green, Brown, Yellow	-	3.54 kg	10 boxes
	Special composite screws for aluminium joist (Box of 50 items)		5.5x45mm T20	Stainless steel	Dark Brown, Light Brown, Dark Grey, Light Grey	-	0.26 kg	60 boxes
SIVIS2112	Dark Brown							
SIVIS2113	Light Brown							
SIVIS2114	Dark Grey							
SIVIS2115	Light Grey							

PLANNING / LAYOUT

GENERAL POINTS

For pedestrian access installations (paths, walkways, etc.), note that deck boards must be laid perpendicular to the direction of movement, especially for public areas. The joists must therefore be installed parallel to the direction of movement.

In the context of private designs, joists are installed in the same direction as the slope of the ground, following the path of water run-off.

The ends of each board must be fixed to a joist in order to eliminate any risk of deformation or breakage. Any overhang must not exceed 25 mm.

To aid installation of finishing items, it is advisable to create the structure with an exterior frame. See section entitled "Decking surround", in page 10

The joists must be evenly spaced, with interaxial distances of no more than 400 mm to support Silvadec wood composite boards. See document PU7V24 on the silvadec.fr website

LAYOUT

For 1 m² of decking, allow an average of:

- 3 lm of joists + possibly an exterior frame
- 2 horizontal brackets with screws
- 1 divider
- 0.8 foldable connectors

If using 138 x 23 boards: About 18 fastening clips, depending on the complexity of the patterns or cuts your decking involves (one fastener at each board/joist junction).

If using 180 x 23 boards: About 14 fastening clips, depending on the complexity of the patterns or cuts your decking involves (one fastener at each board/joist junction).

- Possibly vertical returns (vertical brackets)

TOOLS TO HAVE ON HAND

Non-exhaustive list

For the joists

- Circular or pendulum saw with a blade suitable for cutting aluminium
- Tape measure
- Screwdriver with adjustable torque, without percussion mode so as not to scuff the aluminium
- Bracket
- Mason's rule
- Spirit level

For the boards you may also need (see PU7)

- Drill
- Trimming saw

PREPARING THE GROUND

The ground must be level to enable a stable and secure installation of the pedestals or spacers. If water is pooling, arrange re-profiling of the ground or any other method of evacuating standing water from under the decking.

INSTALLING THE SUB-STRUCTURE

Pedestal-mounted

The pedestals must be located along the joists at the following centre-to-centre distances:

Diagram 1

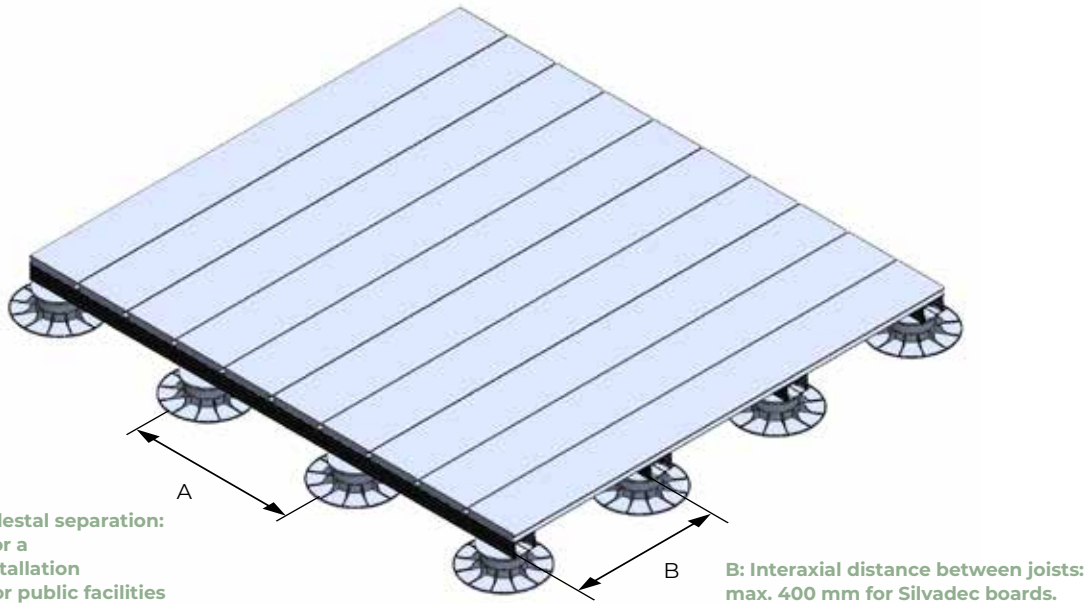

Pedestal type

Silvadec® aluminium joists are compatible with a large number of standard pedestals.

The selection and quality of the pedestals is the responsibility of the installer, and will depend on the clearance height, the total weight of decking to be supported and the slope to compensate.

Each pedestal must be affixed to the joist. To do this, we recommend using pedestals with brackets enabling the joist to be screwed to the pedestal (see diagram below). For example, use stainless steel self-tapping screws, diameter 4.8 mm, length 25 mm (not supplied).

Diagram 2

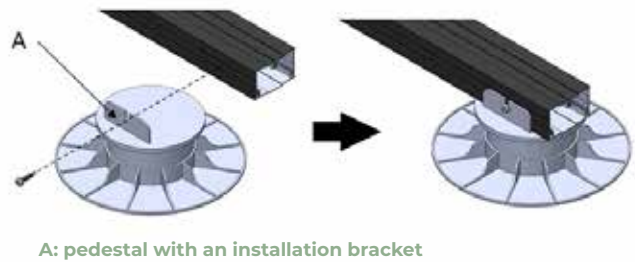

Maximum permitted overhang

The maximum overhang permitted at the end of the joist is 150 mm.

Diagram 3

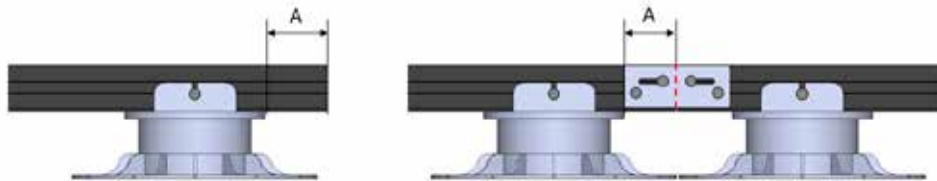

Installing on spacers

When joists are installed on Silvadec® spacers and rubber pads, water can flow freely beneath the joists in situations where the clearance height precludes the use of pedestals. The required distance between the spacers is exactly the same as for pedestals (see Diagram 1, page 5).

Diagram 4



INSTALLING THE STRUCTURE

 **Tip for fitting:** Start by fitting the brackets or connectors using the oblong holes, without fully tightening the screws. When the structure is complete, fit the brackets squarely against the dividers and joists, and then lock the bracket or connector into position by adding an extra screw in each single hole.

Diagram 5



A: oblong holes
B: single holes

Butting joists

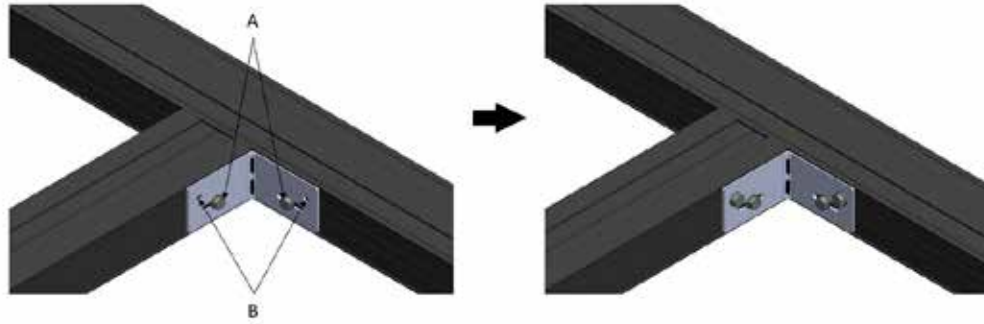
For long structures, joists can be butted together using two connectors.

These help to align the joists, but are not structural elements. The recommendations for supporting the joist ends should be followed (see diagrams 7 and 8).

If a fascia is to be fitted to the decking surround, the exterior connector is optional, so as to avoid creating excessive thickness behind the fascia.

Diagram 6

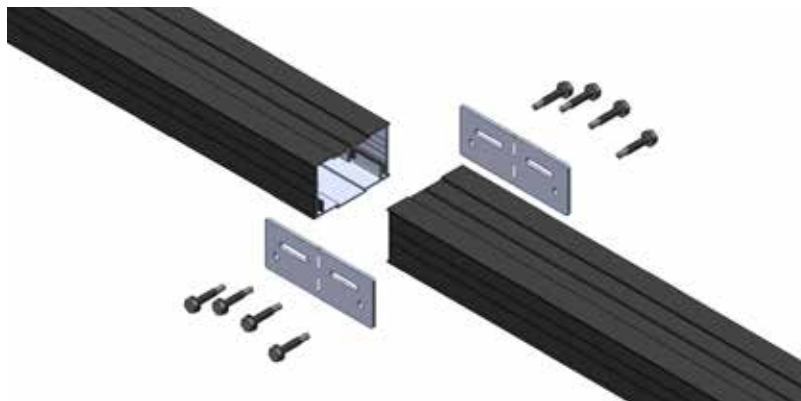

INSTALLING THE STRUCTURE (CONTINUED)

Diagram 7

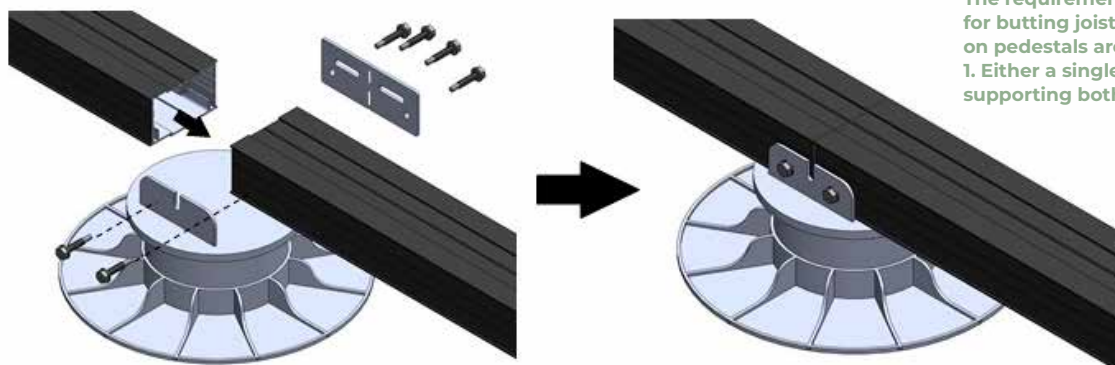

The requirements for butting joists on pedestals are:
1. Either a single pedestal supporting both joists.

Diagram 8

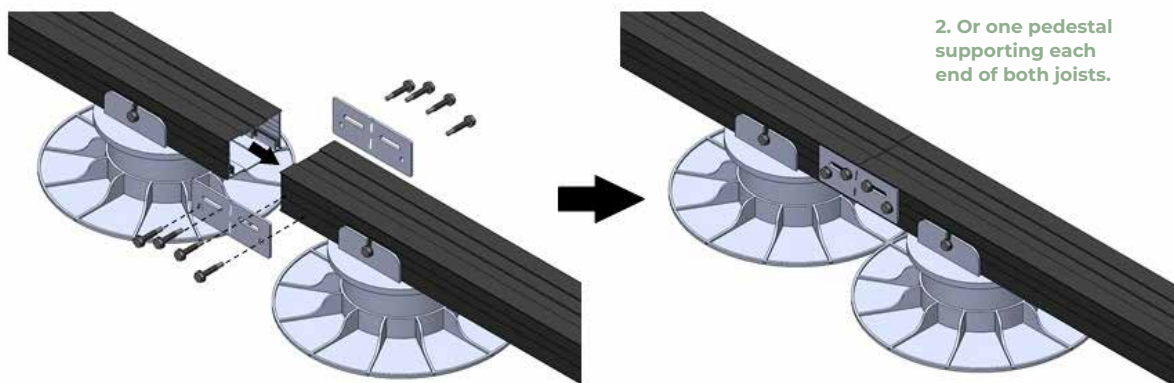

2. Or one pedestal supporting each end of both joists.

Vertical connection as a finish

To trim the structure with finishing boards, use the REVERSIL vertical brackets and H8 screws to connect vertical joists at the end of the structure. To do this, the ends must be cut at an angle of 45°.

Diagram 9

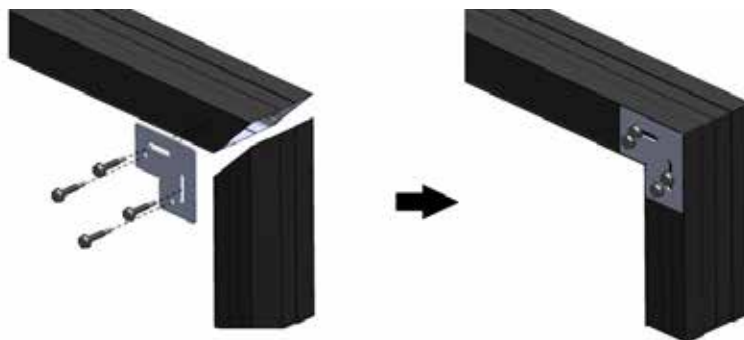

Fit the REVERSIL horizontal brackets lengthwise along the joist, directly on its underside.

⚠ Caution: this should be planned in advance, as there may be insufficient space to tighten screws.

Diagram 10

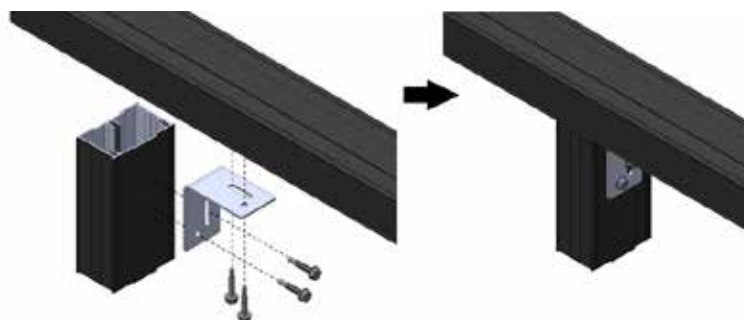

INSTALLING THE STRUCTURE (CONTINUED)

Reversible system for butting boards

With Silvadec® reversible aluminium joists, boards can be butted onto a single joist. To enable this, the joists have two rails on their underside. They therefore need to be turned over, so that a single fastening clip can be fitted to each rail.

Diagram 11



 Butting of boards is described in the section called "Butting boards", page 12.

Affixing dividers

The joists must be connected firmly and solidly together using dividers placed at right angles to the joists. To ensure good structural stability, arrange the dividers in a "ladder" layout, evenly spacing them no more than 2000 mm apart (≤ 1 joist length). See Diagram 12 below.

Diagram 12

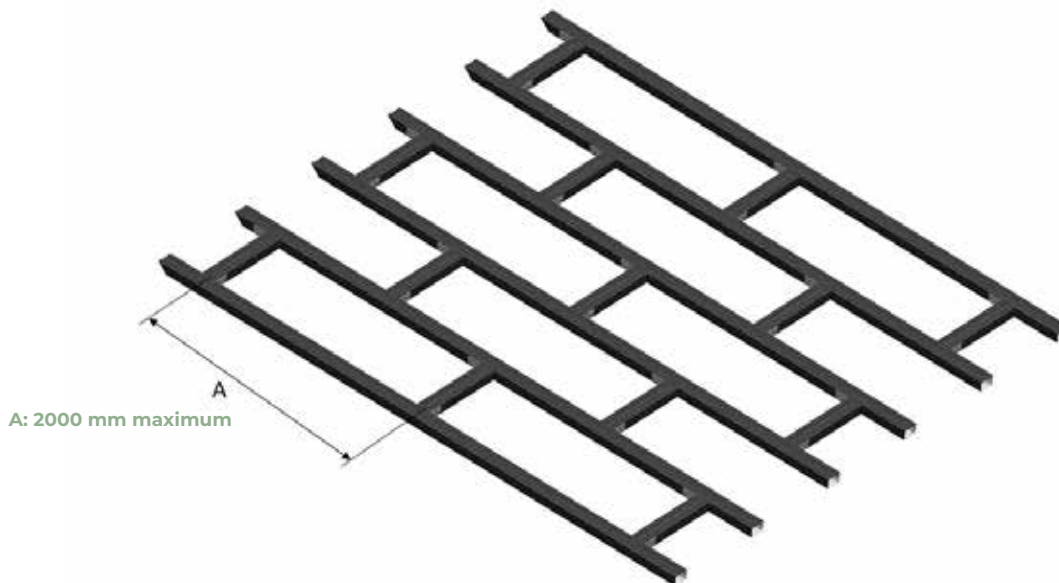
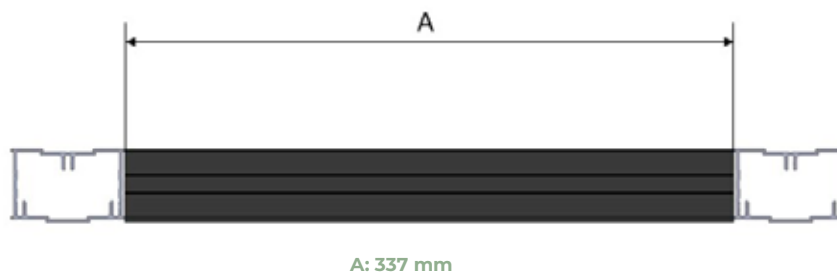

Diagram 13



INSTALLING THE STRUCTURE (CONTINUED)

Each divider is fixed in place by at least two horizontal brackets and the H8 screws provided.

Diagram 14

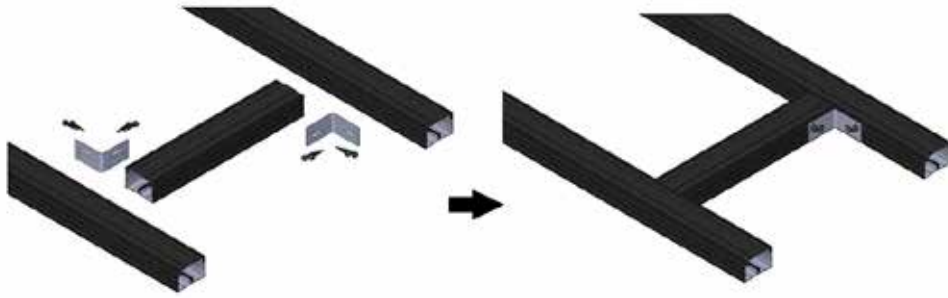
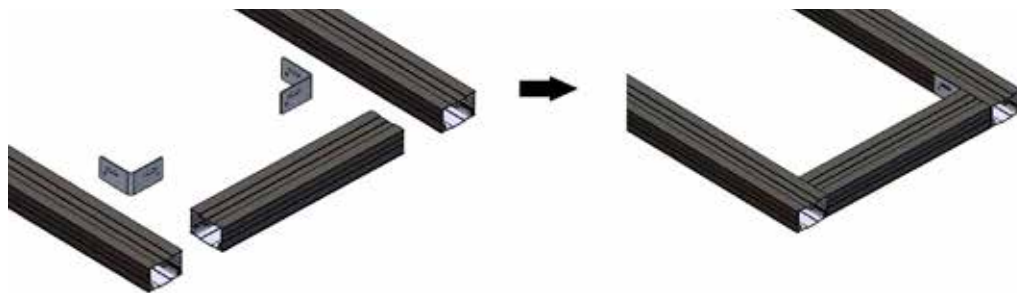

Diagram 15



⚠ Caution: These dividers must not be used to affix the boards.

To create joist-divider assemblies with specific angles (other than 90°), you can fold the foldable connector to set a different fixing angle for your bracket.

Diagram 16

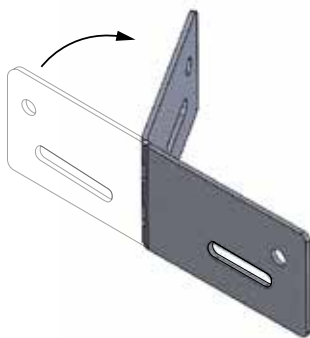

Diagram 17



Decking surround

To create an elegant finish when installing decking, fascia boards or finishing boards can be added. Refer to document PU7. Affix these boards to the aluminium joist using the special composite screws (sold separately) for Silvadec® aluminium joists. There is no need to pre-drill the board or the joist, as these are self-drilling screws. See section entitled "Decking surround, Installing using exposed screws" page 13

To install fascia boards or finishing boards on risers, there are three structural options:

1. OPTION 1: exterior frame with full joists

Diagram 18

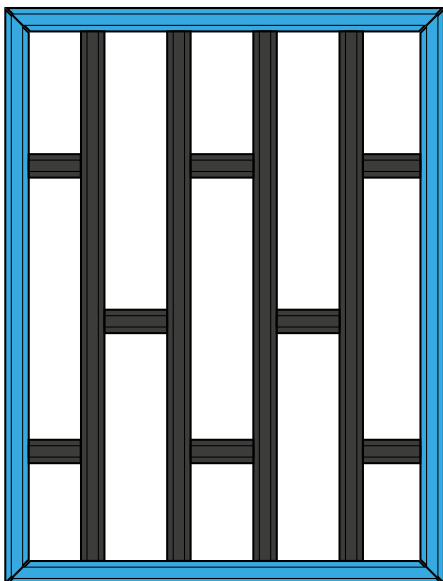
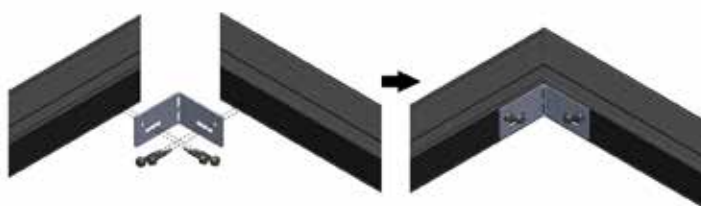

Diagram 19



Note: The ends are cut at an angle of 45°, and held together using a horizontal bracket.

2. OPTION 2: exterior frame with dividers

Diagram 20

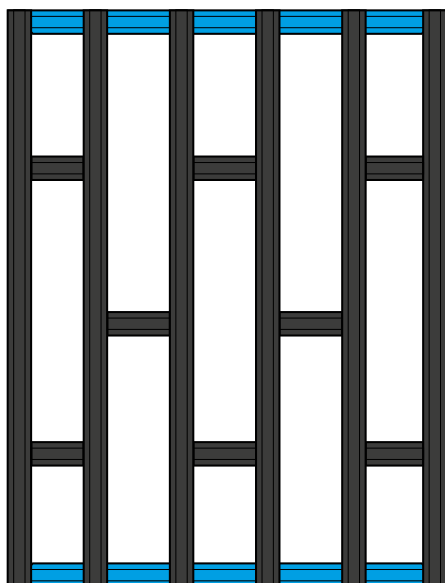

Note: to install dividers, refer to the section on Affixing dividers: page 8

3. OPTION 3: no exterior frame

Diagram 21

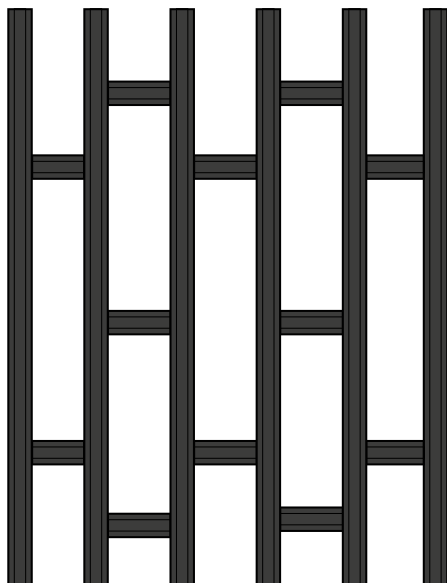

Diagram 22



Note: without an exterior frame, the decking cannot be decorated with fascia boards or finishing boards, because the aluminium joists have hollow ends. To add finishing boards, plan to include vertical returns; see the section on "INSTALLING FASCIA BOARDS AND FINISHING BOARDS ON STAIR RISERS", Diagram 36 page 15 .

Diagram 23

Caution: To be able to affix start and end clips, the joists forming the outside frame must be turned over. See Diagram 11, page 8

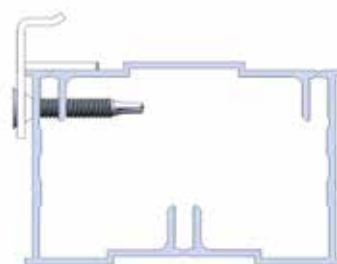

Special case: finishing boards perpendicular to the deck boards

In the particular case where a finishing board is perpendicular to the boards, or marking the edge of an area, it is necessary to:

- Anticipate having a specific frame to support the board.
- Connect this frame firmly to the principal frame using through-screws (not supplied) or foldable connectors.

Diagram 24

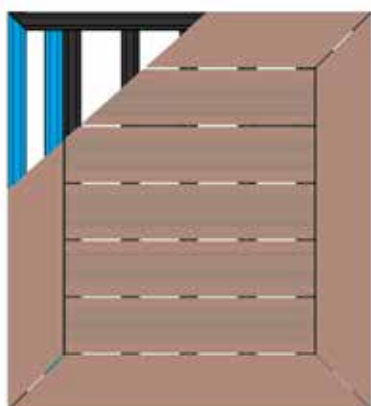
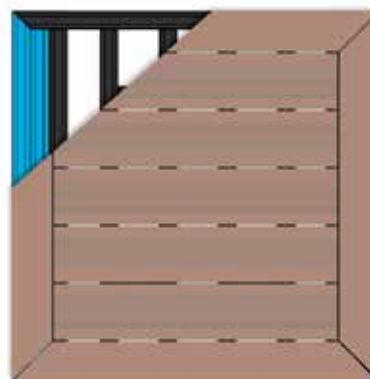

Diagram 25



INSTALLING BOARDS

INSTALLATION WITH SINGLE FASTENING CLIP

To install boards, the joist must be used with the centred rail facing upwards. The centred rail is used for positioning the clip, which is placed under the board. To affix the clips, use stainless steel self-tapping screws for aluminium joists (supplied with the clips).

Diagram 26

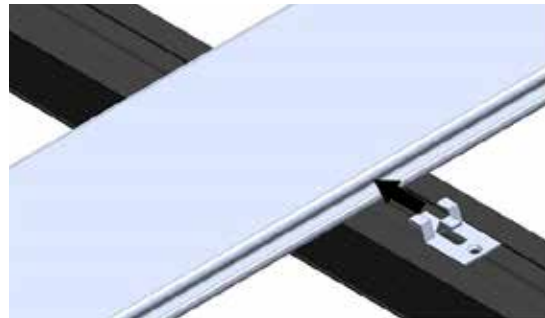
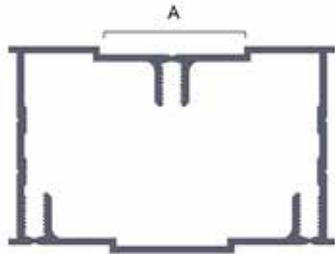

A: Centred rail

BUTTING BOARDS

With Silvadec® reversible aluminium joists, boards can be butted onto a single joist. To enable this, the joists have two rails on their underside. They therefore need to be turned over, so that a single fastening clip can be fitted to each rail.

Diagram 27

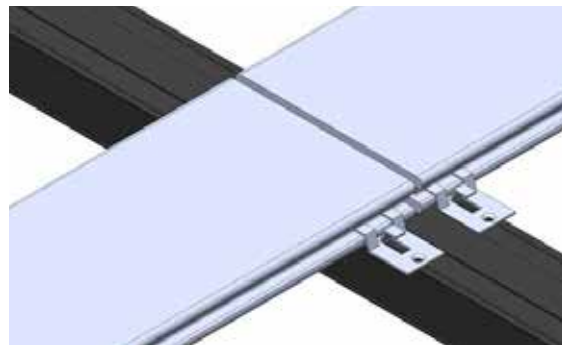
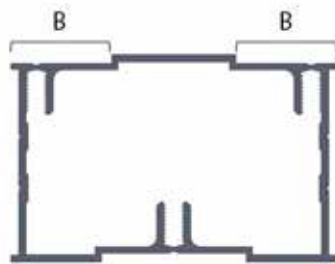

B: Rails for butting

⚠ Caution: Take care to leave a 5 mm expansion gap.

⚠ Caution: Check that this gap is centred on the joist. Cut a little off the board length if necessary. The direction of joist expansion can be fixed – for example, under an aluminium finishing profile – by placing, at a single point, a special composite screw for aluminium joists.

Diagram 28

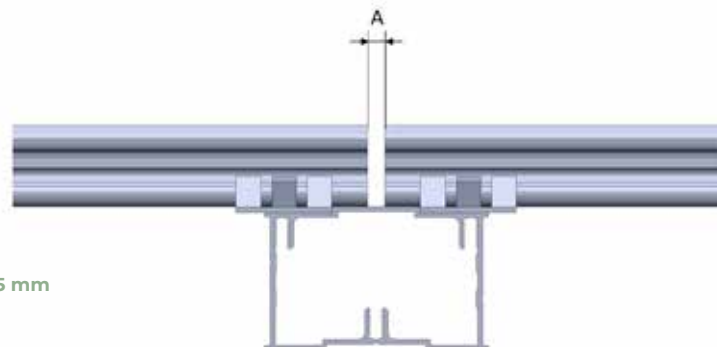

A: At least 5 mm

⚠ N.B.: butting clips are not compatible with this joist.

INSTALLING BOARDS (CONTINUED)

INSTALLING BOARDS OR FINISHING BOARDS AT THE EDGE OF THE DECKING

Installing without exposed screws

Edge boards can be fixed with start and end clips. These clips secure the peripheral boards without exposed screws. Silvadec® boards must be fixed at intervals not exceeding 400 mm.

"Start" position

When it is possible to screw fastenings in from above ("start" position) the clip is screwed into the joist rail.

Diagram 29

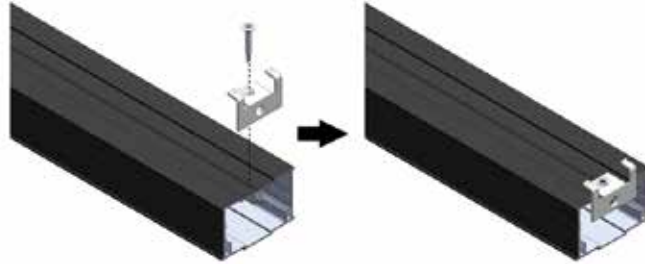

"End" position

When fastenings have to be screwed in from the side, the clip must be placed on a divider, with a maximum interaxial distance of 400 mm.

⚠ Caution: To affix the clip by screwing in from the side, the divider must be turned = centred rail facing downwards.

Diagram 30

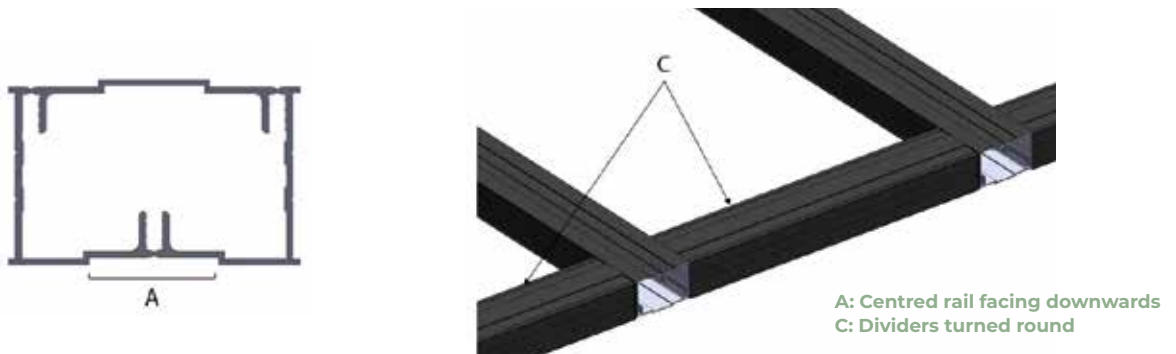

Diagram 31

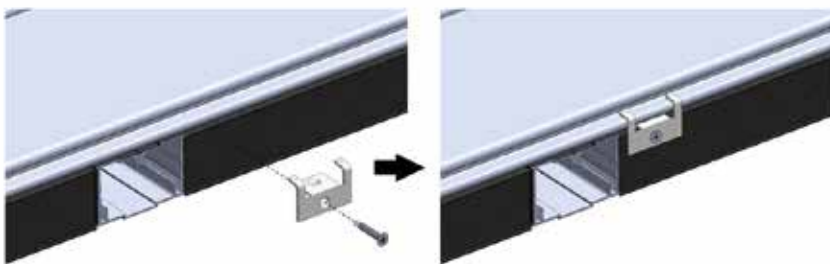
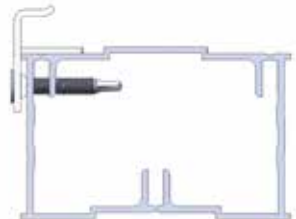

Diagram 32



💡 Comment: in this configuration, the screw goes through two of the joist's walls. It may take a little longer to tighten the screw.

Installing using exposed screws

Silvadec® special composite screw with wings, sold separately.
It is not necessary to pre-drill boards when using this kind of screw.



💡 Tip: for an elegant finish, make a small 45° chamfer for the screw head.

INSTALLING BOARDS (CONTINUED)

It is essential to insert 2 screws at each board/joist junction, i.e. every 400 mm maximum. Except where butting, screws must be positioned so they enter the centred rail of the joist.

Diagram 33

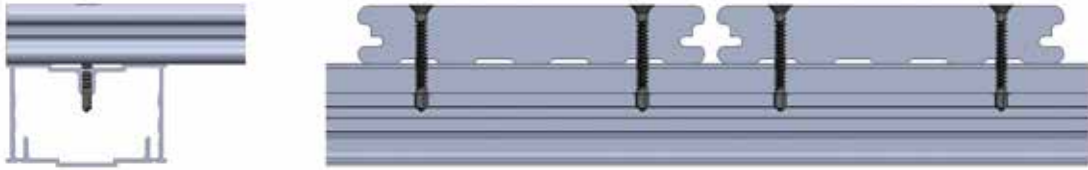

Caution: Screws MUST NOT be inserted less than 25 mm from the edge of the board (even with pre-drilling).

Diagram 34

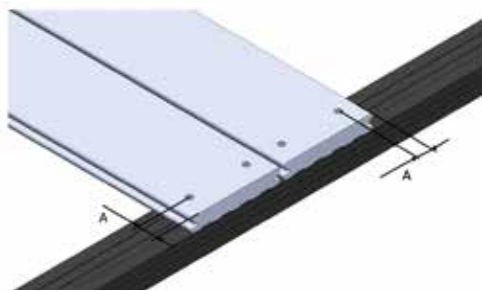

Caution: expansion gaps MUST BE observed (refer to the section entitled "Spacing between boards" in installation instruction PU7 - Deck boards).

REMOVABLE CLIPS

Removable clips are not compatible with this joist. If access under the structure may be needed, plan to have removable elements or access hatches in specific places.

INSTALLING FASCIA BOARDS AND FINISHING BOARDS ON RISERS

Fastening fascias and finishing boards:

Silvadec® special composite screw with wings (sold separately) for aluminium joists
It is not necessary to pre-drill boards when using this kind of screw..

Tip: for an elegant finish, make a small 45° chamfer for the screw head.



OPTION 1: exterior frame with full joists

Fascia boards

Diagram 35

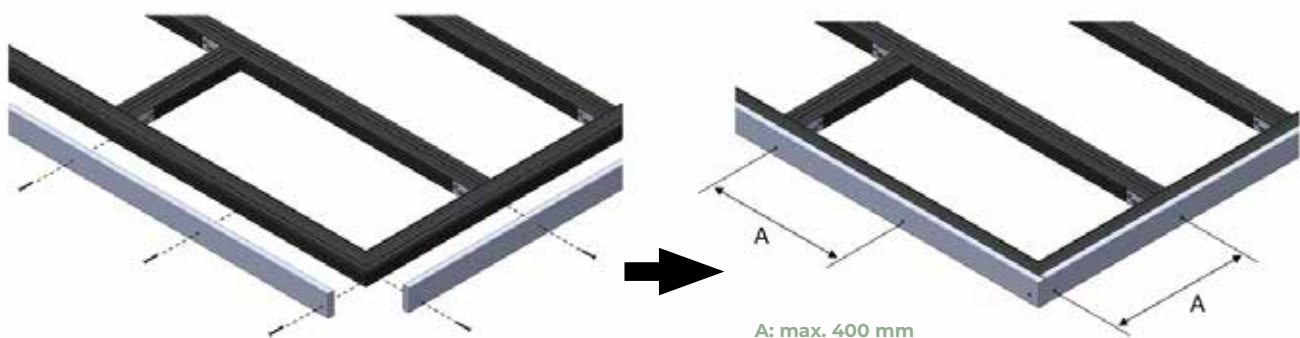

INSTALLING FASCIA BOARDS AND FINISHING BOARDS ON RISERS (CONTINUED)

Finishing boards

Diagram 36

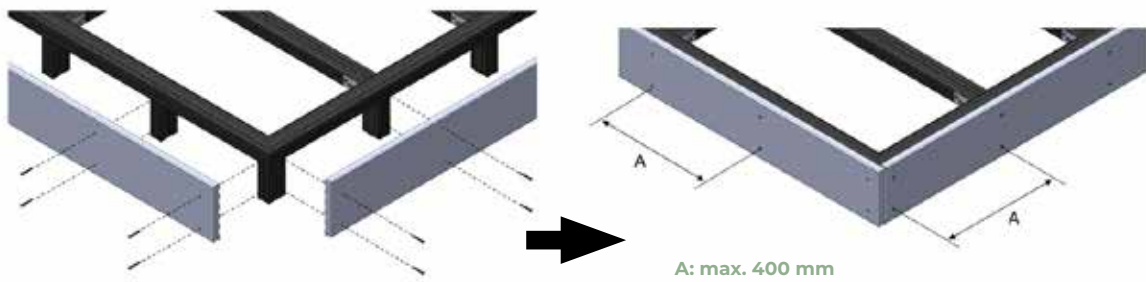

OPTION 2: exterior frame with dividers Fascia boards

Diagram 37

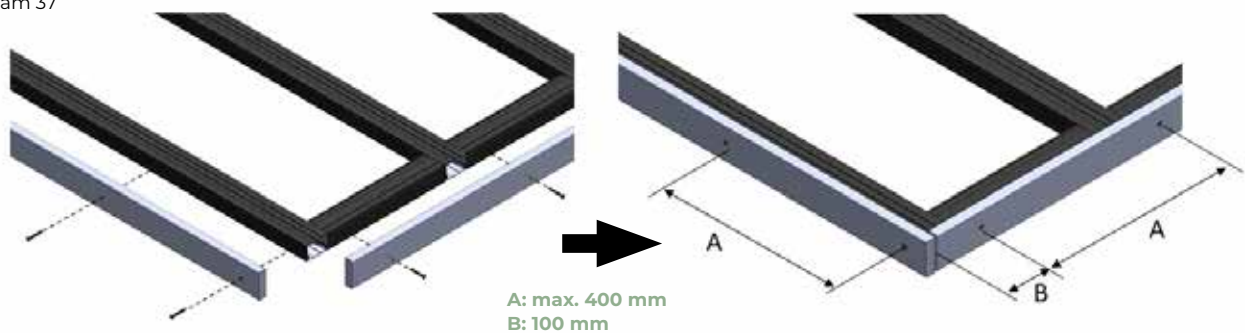

Finishing boards

Diagram 38



OPTION 3: no exterior frame Fascia boards

Diagram 39

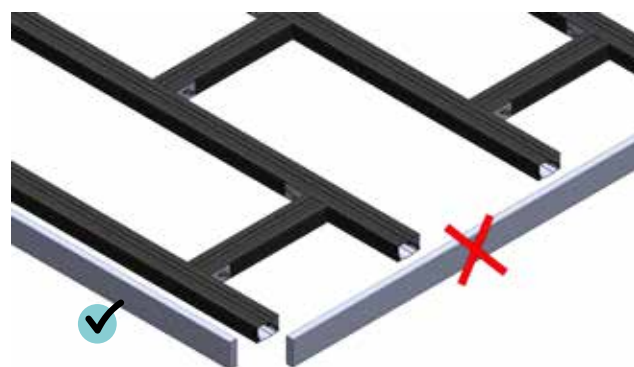

⚠ Caution: Fascia boards cannot be affixed to joist ends. Therefore, this solution is one to consider for decking installed against a wall.

INSTALLING FASCIA BOARDS AND FINISHING BOARDS ON RISERS (CONTINUED)

Finishing board on a riser

Diagram 40

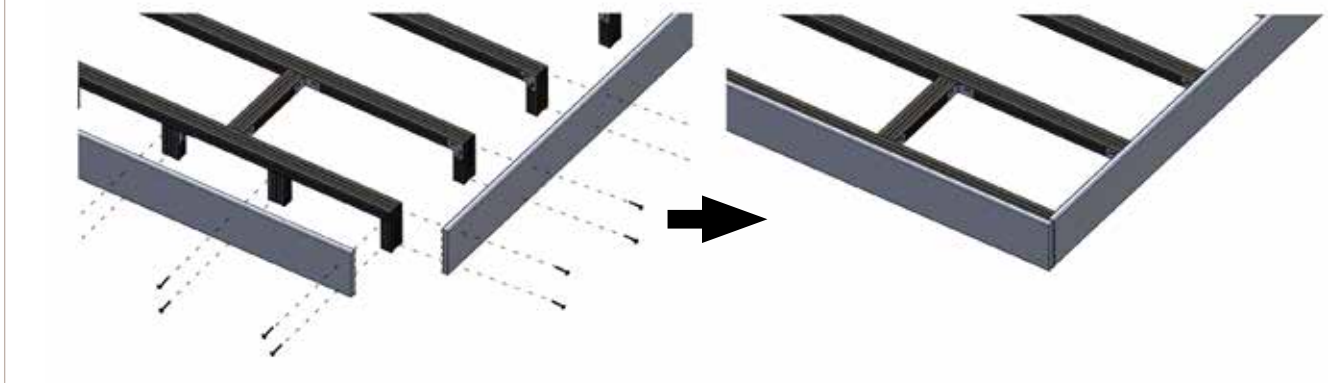

FINALISING THE INSTALLATION

DISCLAIMER NOTICE / GUARANTEE

Consult the decking building code in force in your municipality prior to installation.

Silvadec SA disclaims responsibility and will void its guarantee in the event of failure to follow the instructions above, or if fastening clips or accessories from other manufacturers are used.

MANAGING WASTE ASSOCIATED WITH THE INSTALLATION

Offcuts from aluminium joists can be recycled via the normal channels for recycling aluminium. The small volume of plastic packaging produced is usually not recyclable, and must be taken to the local tip or put in the household waste.

ADVICE ON USAGE

The aluminium joist structure is not visible beneath the decking. Comply with the advised limits on use of the decking (see document PU7).

MAINTENANCE ADVICE

The aluminium joists require no special treatment. Comply with the recommendations on maintaining the decking.

END OF LIFE

DISASSEMBLY

First, disassemble the Silvadec boards.

Next, dismantle the structure, starting with the dividers.

Lastly, detach any pedestals from the joists.

RECYCLING POTENTIAL, AND DISPOSAL

Aluminium joists can be recycled via the normal channels for recycling aluminium.

Elements made of stainless steel (screws, clips, connectors, brackets) can also be recycled via the normal channels for recycling metal.

Plastic adjusting spacers can be recycled via the normal channels for recycling plastic.